

Technology

Sputter-gage Type

Body Material

Stainless Steel

Compression Load Cell

Linearity 0.2%

Achieving precise linearity as high as 0.2% in a compact size.

Screw Mount

Two M2 tap holes on the bottom for screw mounting.

Durable Robot Cable standardized

Enhanced durability against bending that occurs in moving parts with frequent repetitive motion, such as industrial robots and machine tools. High stability and reliability are realized.

Plug & Play with built-in TEDS

With the TD series indicators, equivalent input calibration, likely to forget in manual setting, can be performed automatically and help prevention. (See the reverse page for detail on TEDS)

Specifications

Type	Compression Load Cell		
Model	TC-NSRSP(T)□□N-G3		
			<div style="background-color: #e91e63; color: white; padding: 2px; display: inline-block;">TEDS</div> (Embedded in the body) <div style="background-color: #008000; color: white; padding: 2px; display: inline-block;">RoHS</div> (10 substances)
Rated Capacity (R.C.)	Unit	Natural Frequency	Weight (Approx.)
	50N	41.8kHz	17g
	100N	60.9kHz	17g
	200N	83.3kHz	17g
	500N	116.9kHz	17g
Safe overload rating	150 % R.C.		
Rated Output (R.O.)	1.3mV/V ±30%		
Linearity	0.2% R.O.		
Hysteresis	0.2% R.O.		
Repeatability	0.2% R.O.		
Safe Excitation Voltage	5V		
Input Terminal Resistance	1150Ω ±30%		
Output Terminal Resistance	1150Ω ±30%		
Insulation Resistance	1000 MΩ or more (DC 50 V)		
Compensated Temperature Range	0°C to 60°C		
Permissible Temperature Range	-20 to 70°C		
Temperature Effect on Zero Balance	0.3% R.O. / 10°C		
Temperature Effect on Output	0.3% R.C. / 10°C		
Cable	Φ3, 6-core shielded, 3m direct connection robot cable with bare lead wires		
Mounting Method	Screw holes		
Body Material	Stainless Steel		

Dimensional drawings (Units: mm)

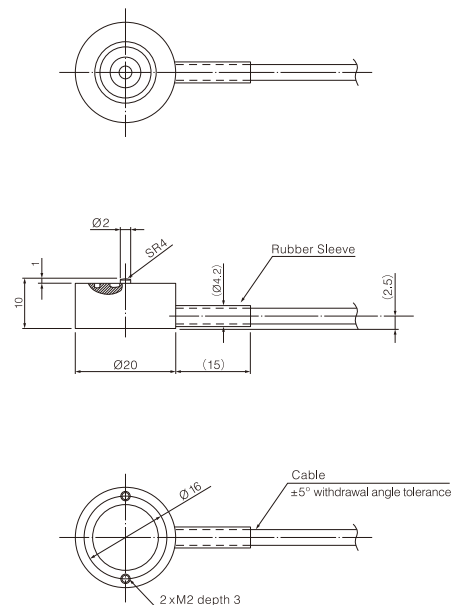

TEAC Load Cells

Since the 1980s, when TEAC started manufacturing and selling load cells, we have cultivated technologies to achieve higher precision and smaller size with our unique structures. With these technologies, a number of load cells that achieve high response, high accuracy, and high stability, as well as products that take environmental conservation into consideration have been developed to match customers' applications.

We also offer customization for specific conditions (usage environment, space) that are difficult to meet with standard ones. From one-off prototypes to mass production, we support engineers involved in research and development on manufacturing technology.

Examples of application

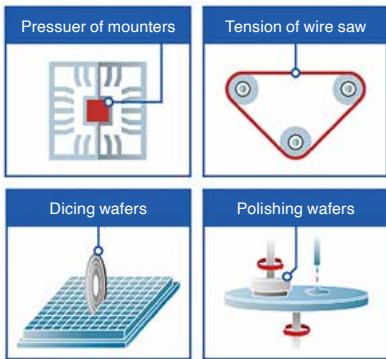

Robot Cable standardized

Robot cables provide enhanced durability and stable performance against bending that occurs in moving parts with frequent repetitive motion, such as industrial robots and machine tools.

Every TEAC's ultra-compact load cells employ robot cables, together with the TEDS function, contribute to factory automation and labor savings.

* Customized proposals that match your application and environment are available. Please contact our sales representatives for detail.

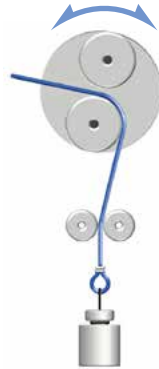

As shown above, fix the core wire so that it does not move, bend it 90 degrees to the left or right, and confirm that no wire breakage occurs.

TEDS-compatible

The TEDS (Transducer Electronic Data Sheet) system is a generic term for a description format standardized by IEEE that electronically reads and writes sensor's specific characteristic, which is recorded in an EEPROM built into the sensor and can be read and written electronically.

Model name, serial number, sensitivity (output value against physical quantity) and other calibration factors are digitized and recorded in the memory built into the load cell body. Sensor's specific values can be set electronically, automating the reading of recorded information and equivalent input calibration, eliminating human error in setting and reducing the burden of load cell replacement.

Load Cell Embedded Equipment TEDS-compatible digital indicators



Sending individual specific values of each load cell indicated in the unit's Data Sheet

TEAC has been strongly promoting TEDS (IEEE 1451.4 Transducer Electronic Data Sheet) compliance for load cells and load cell indicators. We are the first Japanese manufacturer that obtained a "Manufacturer ID", making our load cells and indicators TEDS-compatible.

Related Products (Indicators and Signal Conditioners)



92 x 92mm
Panel opening size

Color Graphics Digital Indicator

TD-9000T

NPN type (Standard) **PNP type**
Standard model Standard model
EtherNet/IP™ model EtherNet/IP™ model
CC-Link model CC-Link model

High performance model with large LCD

Supporting two inputs, force sensor and displacement sensor, various comparison judgments function, and direct saving of waveform data onto large capacity internal memory.

US CE CC-Link
EtherNet/IP



92 x 45mm
Panel opening size

Digital Indicator

TD-700T

Standard model
CC-Link model
RS-485 model

Excellent model with compact and high functionality

Supporting five key functions in one unit, numeric display, graph display, TEDS function, static strain display, and signal conditioner.

This small and cost-effective TD-700T achieves equal or even higher performance to upper-class models, with high-visibility color LCD and various hold functions.

US CE CC-Link



Attaches to common DIN rails

Signal Conditioner

TD-SC1

D/A model
RS-485/Modbus RTU model
CC-Link model
EtherNet/IP™ model

Slim and light-weight signal conditioner

Supporting high-speed sampling of 20,000 times/second, PC-based configuration via USB connection, selectable network, and TEDS calibration function.

US CE UK CA
CC-Link EtherNet/IP



Weighs only 320g
(incl. batteries)

Portable Digital Indicator
TD-01 Portable

On-site checking tool with versatility

Supporting various functions that equal to embedded systems, in hand-held size, allowing you to take measurements anytime anywhere, according to your purpose.

CE